

Volvo 1800S 1969 Wiring Diagram

(Chassis # 28301 to 29993) Model S

Wiring Diagram Version: V3.0 Date: Dec 2023

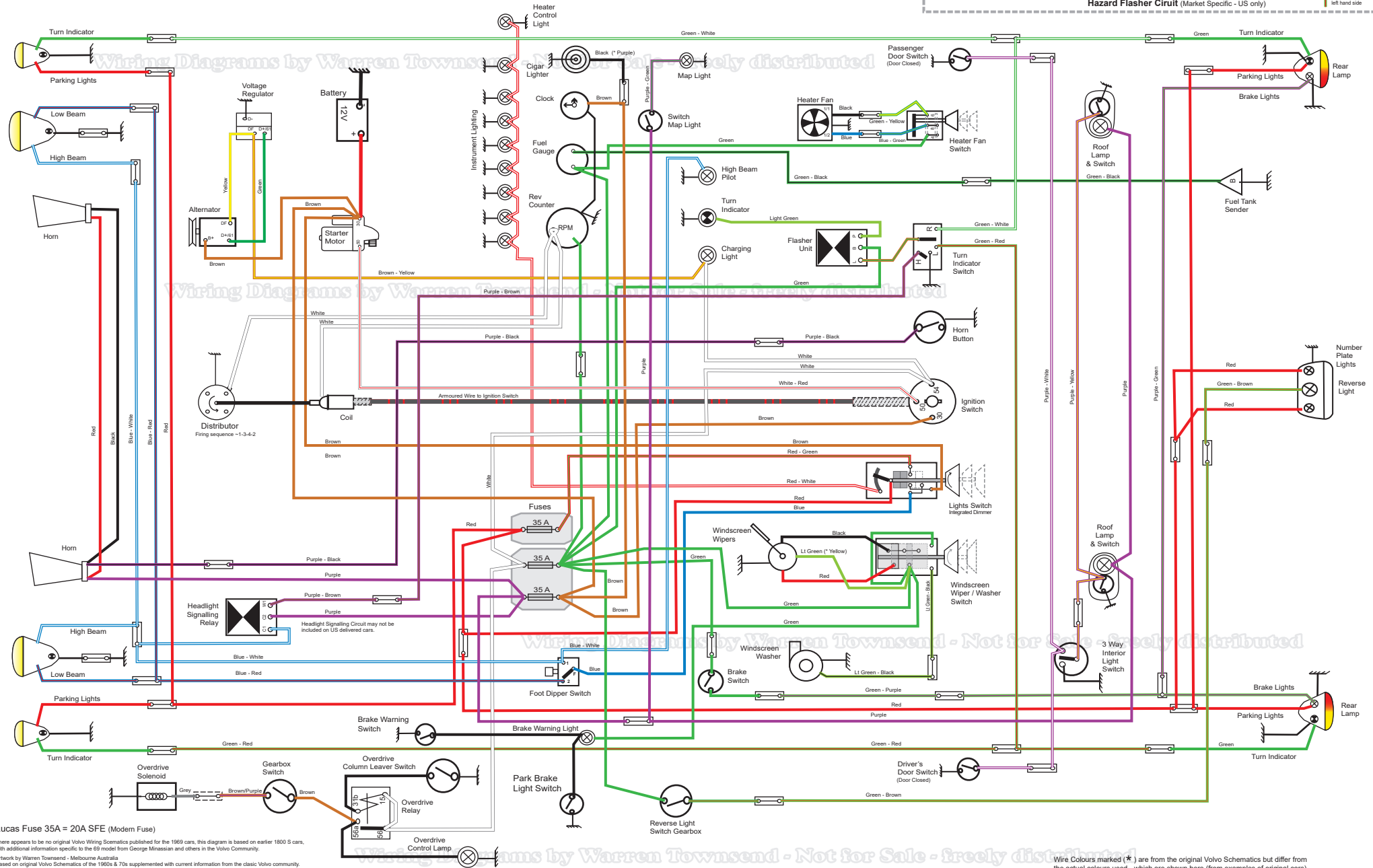
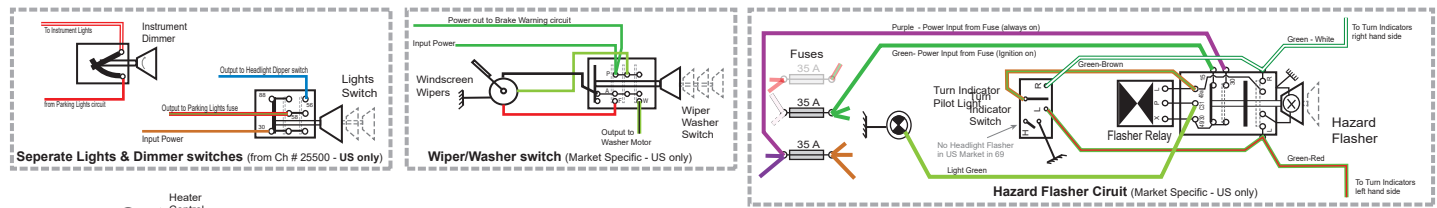

Lucas Fuse 35A = 20A SFE (Modern Fuse)

There appears to be no original Volvo Wiring Schematics published for the 1969 cars, this diagram is based on earlier 1800 S cars, with additional information specific to the 69 model from George Mianian and others in the Volvo Community.

Artwork by Warren Townsend - Melbourne Australia
Based on original Volvo Schematics of the 1960s & 70s supplemented with current information from the classic Volvo community.

I have attempted to make these Wiring Diagrams as accurate as possible, however no responsibility is accepted for any consequential errors from their use.

Diagrams will be updated as extra information comes to hand, please check your distribution source for the most recent versions.

I have used Dashed Lines --- to indicate Optional, or Market Specific Components.

*** In some instances Volvo made mid run production changes, please also reference previous, or subsequent year's schematics. ***

Wire Colours marked (*) are from the original Volvo Schematics but differ from the actual colours used - which are shown here (from examples of original cars).