

# Volvo 1800S 1965 - 1968 Wiring Diagram

- (Chassis # 12500 to 28300 ) Models VE/HE, VF/HF, M, P.

Wiring Diagram Version: V2.8 Date: April 2023

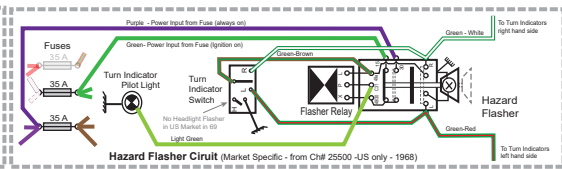
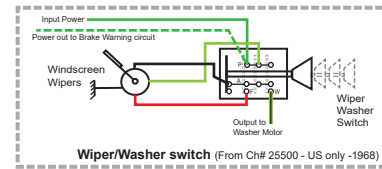
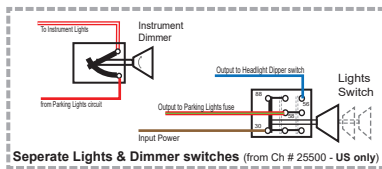

From Chassis # 25500 MY68 New electrical circuits were introduced into US Market cars. New Switches for Wiper/Washer, Hazard Flashers and Lights (all USA only) but the relevant wiring circuits were not included on Volvo Wiring Diagrams of the time. Those market specific circuits are shown above.

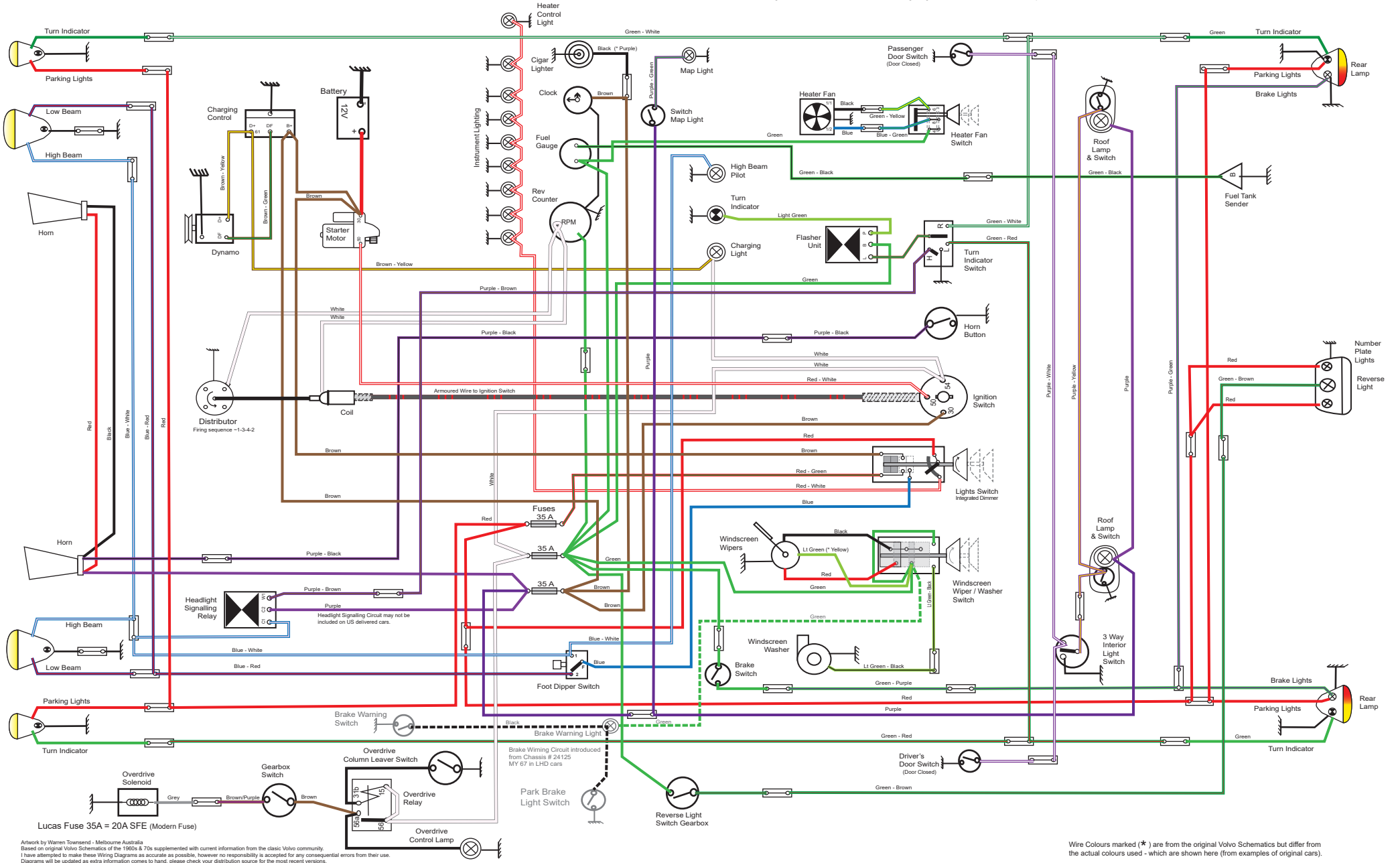

Lucas Fuse 35A = 20A SFE (Modern Fuse)

Artwork by Warren Townsend - Melbourne Australia  
 Based on original Volvo Schematics of the 1960s & 70s supplemented with current information from the classic Volvo community.  
 I have attempted to make these Wiring Diagrams as accurate as possible, however no responsibility is accepted for any consequential errors from their use.  
 Diagrams will be updated as extra information comes to hand, please check your distribution source for the most recent versions.  
 I have used Dashed Lines --- to indicate Optional, or Market Specific Components.  
 \*\*\* In some instances Volvo made mid run production changes, please also reference previous, or subsequent year's schematics. \*\*\*

Wire Colours marked (\*) are from the original Volvo Schematics but differ from the actual colours used - which are shown here (from examples of original cars).